

| Model | Description | Kvs |
|------------------|-----------------------------|-----|
| Two-way | | |
| VSE1 | Motorized Valve DN1/2" n.c. | 2,2 |
| VSE2 | Motorized Valve DN3/4" n.c. | 3,0 |
| VSE3 | Motorized Valve DN1" n.c. | 6,9 |
| Three-way | | |
| VDE1 | Motorized Valve DN1/2" n.c. | 2,6 |
| VDE2 | Motorized Valve DN3/4" n.c. | 3,4 |
| VDE3 | Motorized Valve DN1" n.c. | 6,9 |

APPLICATION AND USE

VSE/VDE motorized valves provide easy installation for a variety of heating and cooling applications. Valve's actuator can be installed after valve body has been installed onto fan coil, baseboard or air handler.

GENERAL CHARACTERISTICS

- Direct replacement for all existing two-position applications.
- Hysteresis synchronous motor for long life.
- Spring return operation provides a fail-safe.
- Actuator mounts directly onto valve body without need for linkages or calibration.
- Manual override lever.
- VSE-VDE valves are maintenance-free
- Actuator can be replaced without any tools, or removal of valve from system.

TECHNICAL CHARACTERISTICS

VALVE BODY

| | |
|-------------------------------|---|
| System static pressure limits | 2,000 kPa (20 bar) |
| Close-off | See table |
| Temperature limits: | |
| - ambient | T40 °C |
| - fluid | T93 °C |
| Allowed fluids | Hot and chilled water, water with up to 50% glycol. |
| Leakage | ANSI class IV (0.01%) |
| Body | Forged brass |
| Stem | Nickel-plated |
| Seat | Brass |
| Paddle | Buna N |

| DN | Connection type | Close-Off Delta p kPa |
|------|-----------------|-----------------------|
| 1/2" | Female thread | 276 |
| 3/4" | | 172 |
| 1" | | 117 |

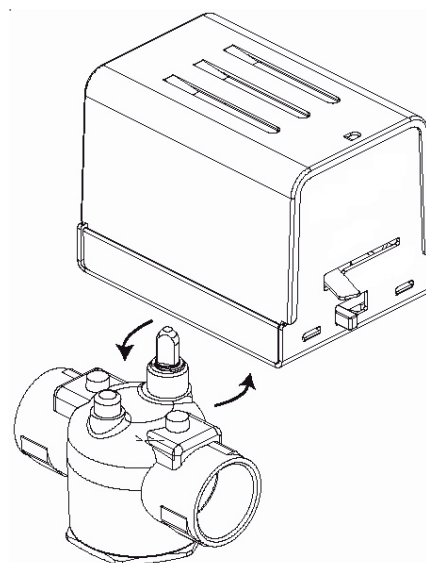

ACTUATOR

| | |
|----------------------------------|--|
| Voltage | 230 Vac - 50 Hz |
| Power requirements | 6.5 W, 7.5 Va. |
| Control signal | On/off, 2 position, spring return |
| Timing | 30 Sec max for 50 Hz, 9 sec spring return |
| Materials | Stainless steel base plate, aluminium cover. |
| Room temperature limits | |
| - working | T40 °C (fluid max 93°C) |
| - storage | -40T71 °C |
| Humidity | 5 to 95% R.H., non-condensing |
| Weight (Actuator/valve assembly) | 1.02 kg |

Product conforms to EMC (89/336/EEC) and LVD (72/23/EEC) directives. It is a Class B product, therefore, in a domestic environment it may cause radio interference.

OPERATION

VSE-VDE are two position spring return valves. When powered, the actuator moves to the desired position, tensing the spring return system. When power is removed the actuator returns to the normal position. Two position spring return valves are equipped with an optional built-in auxiliary SPDT end switch for interfacing or signalling; for example, zone pump burner control.

INSTALLATION

Use a 25 to 40 mm wrench (not provided). Installer must be a qualified, experienced technician.

General precautions

- Electrical shock hazard! Disconnect power before installation to prevent electrical shock or equipment damage.
- Make all connections in accordance with the electrical wiring diagram and in accordance with national and local electrical codes. *Use copper conductors only.*
- All conductors shall be provided with insulation rated for the highest voltage motor and end switch circuits.

The valves can be mounted in horizontal or vertical piping. When installed in horizontal piping, the actuator must be above the valve body. When installed in horizontal piping the actuator can be tilted left or right but it must not be tilted below 85° from vertical.

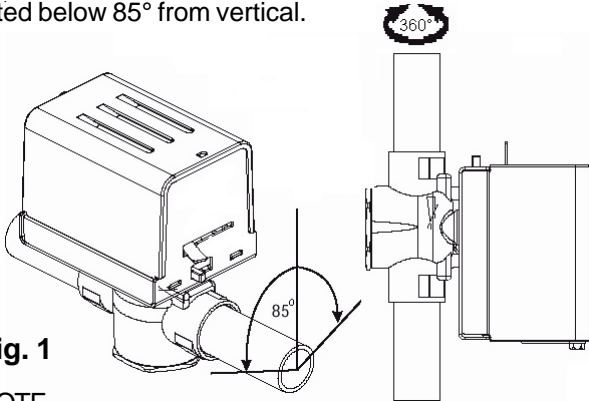

Fig. 1

NOTE

- Make certain there is no overhead water source that may drip onto valve actuator.
- In normal service, some condensation may occur on or around the valve. A drip pan may be necessary or the valve body may be insulated.

PIPING

The valves must be piped so that the paddle closes against the direction of flow. Flow is from B to A (Refer to schemes Figure 2).

When installing the actuator to a normally closed valve, the actuator must be placed in the manually open position by using the manual operating lever.

The first time the valve is operated electrically, the manual operating lever of the actuator will transfer to the automatic position. The manual operating lever can be used to allow flushing of the system after installation.

The valves are designed for application in closed hydronic heating and cooling systems. High levels of dissolved oxygen and chlorine found in open systems may attack the valve materials and result in premature failure.

Install over a drip pan if condensation in chilled water applications occurs.

CAUTION: Use in systems which have substantial make-up water (open systems) is not recommended.

In order to mount the valve onto the pipe, apply Teflon tape to all but the last two threads of male pipe thread. Hand screw the pipe into the valve, turning it as far as it will go. Use a wrench to fully tighten the valve to the pipe. Do not over tighten or strip the threads.

NOTE

- Three-way valves are always closed at the B port when no power is applied to the motor.
- On power-up the valve closes to A port on three-way valves.
- Orient the three-way valve body as needed for normally open or normally closed flow through coil.

PIPING SCHEMES

Two-way

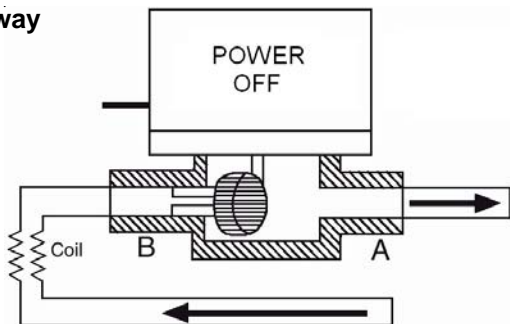

2-Way Valve with Normally Closed Actuator

Tre vie

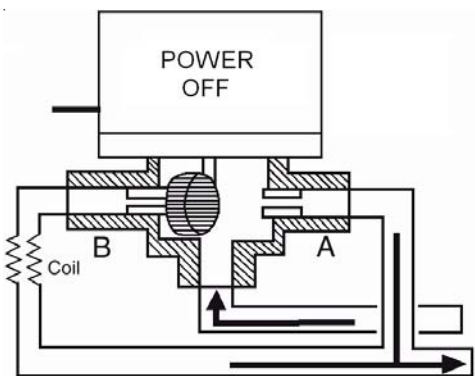

3-Way Valve in Diverting Configuration Normally Closed to the Coil

Three-way

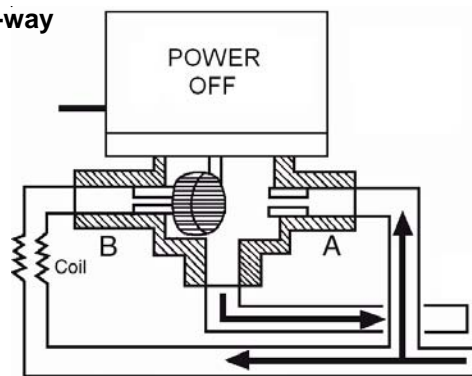

3-Way Valve in Mixing Configuration Normally Closed to the Coil

Fig. 2

NOTE: Three-way N.O. applications can be achieved when using a N.C. actuator, by piping the valve in reverse. The three-way examples show normally closed actuators.

INSTALLING ACTUATOR ON VALVE BODY

Slowly latch the manual operating lever in the open position.

Depress the release button (see Figure 3). Align the body with the actuator to ensure the stem is inserted into the large mating hole on the bottom side of the actuator. Engage the actuator on the body and release the button.

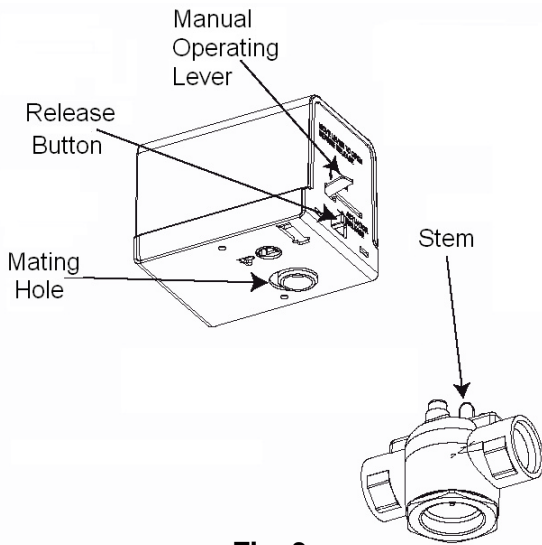

Fig. 3

CAUTION

Do not use the valve body to manually open the actuator as damage to the valve actuator will result.

CHECKOUT

- Make sure the valve stem rotates freely before and after installing the actuator.
- If the stem does not operate freely it may indicate that the stem was damaged and may require that the valve be repaired or replaced.
- After the piping is under pressure, check the valve body and the connections for leaks.
- After the valve and actuator are installed, power the actuator and check the operation.

WIRING DIAGRAMS

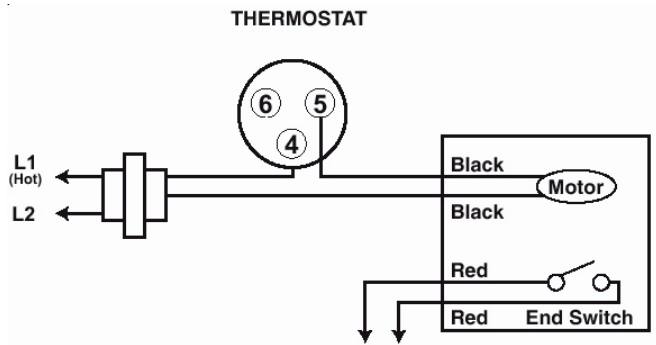
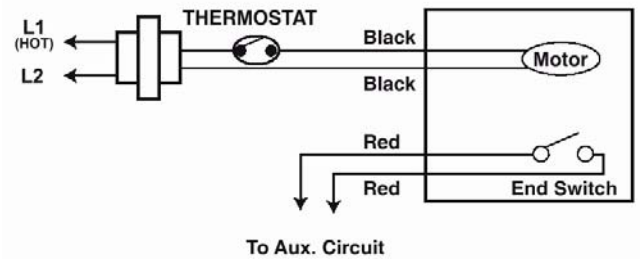

OVERALL DIMENSIONS (mm)

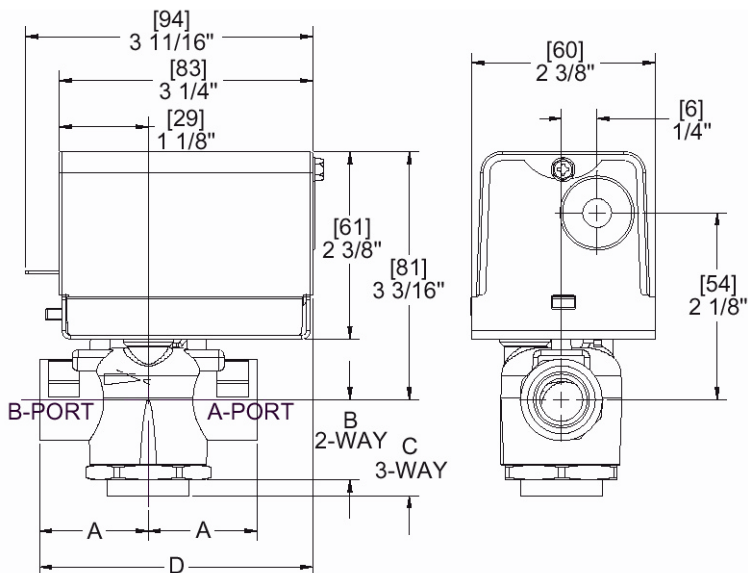

| Valve body | A | B | C | D |
|------------|----|----|----|----|
| 1/2" | 35 | 23 | 33 | 86 |
| 3/4" | 43 | 23 | 37 | 92 |
| 1" | 47 | 25 | 43 | 94 |

The performances stated on this sheet can be modified without prior notice due to design improvements.